

SYNGAS FUELED CHEMICAL LOOPING COMBUSTION (CLC) POWER PLANT - EXERGY ANALYSIS

A.YERRAYYA, P.V. SURESH*

Department of Chemical Engineering, National Institute of Technology, Warangal-506004, India.

(Received 16 December, 2015; accepted 12 June, 2016)

Keywords: Exergy, Chemical looping combustion, Syngas, Power plants, Exergy efficiency

ABSTRACT

The continuous increase in the demand for quality power necessitates the operation of power plants in most energy efficient manner. This requires exergy analysis in addition to the energy analysis for any plant. In this study, a 50 MW syngas fuelled power plant with chemical looping combustion (CLC) implementation, where a conventional combustion chamber is replaced by a two reactor setup-fuel reactor followed by air reactor, is considered. An exergy analysis by means of exergy efficiency and exergy destruction efficiency for different units in this plant is presented. The analysis concludes that any developments/changes to be carried out in the plant to improve the overall thermal efficiency of the plant have to be directed towards the fuel reactor as the exergy destruction efficiency of the fuel reactor is found to be more among all other units. This study employs an Aspen Plus model to investigate the effect of air mass flow rates on the thermal efficiency.

INTRODUCTION

Increased concentration of carbon dioxide (main constituent of the greenhouse gases) in the atmosphere, released by the combustion of fossil fuels is one of the major environmental threats of the present world. Usage of fossil fuels is inevitable and it will continue to be the primary source, as energy demand is increasing exponentially day by day (Figueroa, et al., 2008). Using fossil fuels without CO₂ emissions is possible by two ways-separation of CO₂ and storage. Separation can be done by using different technologies such as post-combustion, pre-combustion and oxy fuel combustion. All these techniques have a common disadvantage of high energy penalty for separation of gases (in order to obtain the CO₂ in pure form). This energy penalty can be overcome by using chemical looping combustion technique. It is an energy efficient technique to separate CO₂ from the flue gases, with the aid of an oxygen carrier.

Chemical looping combustion (CLC) system consists of two reactors-one is air reactor and other is fuel reactor. These reactors are usually operated as interconnected fluidized beds (Adanez, et al.,

2012; Erlach, et al., 2011). Nickel oxides (NiO) are generally used as oxygen carriers for syngas fuel. In air reactor, Ni is entrained in a fluidized bed with air as the fluidizing agent, where Ni reacts with oxygen to produce NiO according to the Eq. (1). NiO is then separated from N₂ and transferred to the fuel reactor. In fuel reactor, NiO reacts with synthesis gas to produce CO₂ and H₂O according to the Eqs. (2) and (3). Reduced Ni is recycled back to air reactor. This process continues and pure CO₂ stream would be available after the condensation of water. A schematic representation of Chemical looping combustion process is shown in Fig. 1.

In air reactor



In fuel reactor

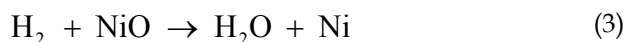
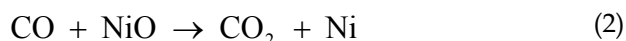

Overall reaction



The demand for quality power production is increasing continuously and this imposes the power

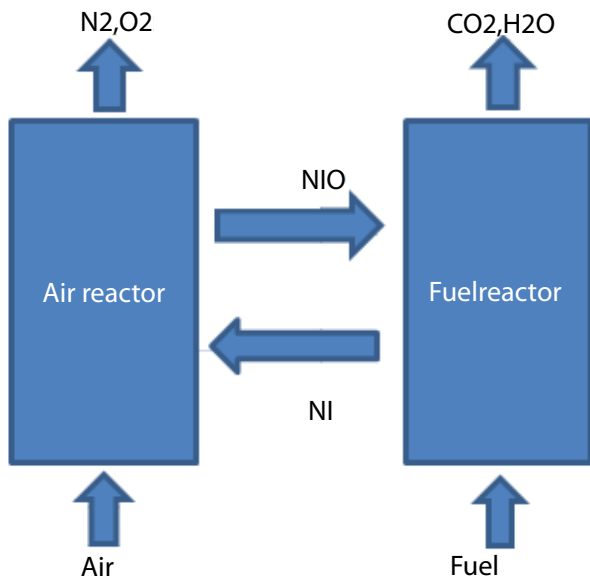

Fig. 1 Principle of chemical looping combustion

plants to operate in most energy efficient manner. Most of the power plants are generally designed by the energy performance criteria based on first law of thermodynamics. This energy analysis gives only quantitative results, while the exergy analysis which is based on the maximum useful work, presents qualitative results of the actual energy conversion. The exergy of a material stream can be decomposed into thermal, mechanical and chemical components. Physical exergy which is sum of thermal and mechanical exergies can be obtained from entropy-production flow, whereas chemical exergy is the maximum work that can be obtained when the considered system is brought into reaction with reference substances present in the environment.

(Bilgen et al., 2008) calculated the chemical exergy of various fuels by using equations given in the literature to detect and to evaluate quantitatively the effect of irreversible phenomena which finally leads to the thermodynamic imperfection of the processes. (Wang et al., 2013) presented the energy and exergy analysis of the hydrogen fueled power plant with inherent CO₂ capture based on calcium looping process. They concluded in their analysis that the combustion chamber and regenerator were responsible for large exergy destructions. An analysis on the energetic performance of gas turbine based cycles with chemical looping combustion and a comparison with similar systems with conventional combustion, when syngas from gasification of biomass is used as fuel and iron oxides as oxygen carrier are studied by (Jimenez Alvaro et al., 2014). They further presented the results about the energetic performance of an IGCC plant based on CLC with CO₂ sequestration (Jimenez Alvaro, et

al., 2015) (Kaushik et al., 2011) carried out energy analysis of IGCC with CLC, based on the first law of thermodynamics and also performed exergy analysis based on the conservation of mass and degradation of the quality of energy along with the entropy generation to complement the energy analysis. (Al-Doori et al., 2012) performed an exergetic analysis for a Baiji plant with a gas-turbine of capacity 159-MW and concluded that the exergy destruction taking place in the combustion chamber was high and the inlet temperature of turbine had an effect on both the exergetic efficiency and the exergy destruction in the plant. (Erlach et al., 2011) studied the CLC integrated IGCC theoretically using Aspen Plus and compared the results with a conventional IGCC with pre-combustion carbon capture by physical absorption. (Mukherjee et al., 2015) compared the characteristics of three CO₂ capture technologies such as CLC, pre-combustion and oxy-fuel combustion with a conventional IGCC plant without CO₂ capture by performing the energy analysis.

Even though many studies are available on the energy analysis of different power plants including IGCC and CLC integrated plants, only few studies are available on the exergy analysis of CLC integrated power plants and on the effects of key operating parameters on the overall plant performance. In this work, an attempt has been made to perform an exergy analysis of a 50 MWth syngas fuelled power plant integrated with CLC utilizing Nickel Oxide (NiO) oxygen carrier. It is necessary to conduct this kind of studies to run the CLC integrated power plants with inherent CO₂ capture in the most economic and effective way. The present study focuses on determining the effect of air flow rate and fuel flow rate on the overall thermal efficiency of the plant and exergy destruction losses in different key units involved in the power plant and identifying the units with highest exergy destruction. The units with lower exergy efficiencies or higher exergy destruction losses will be the culprits in lowering the overall thermal efficiency of the plant. Hence, the outcome of the study would be useful in getting the information on the possible units to be given attention in order to increase the overall plant performance.

METHOD OF EXERGY ANALYSIS

The term Exergy refers to the Greek words ex (external) and ergos (work). The term is also described as Available Energy or simply Availability. Szargat et al., defined exergy as: "Exergy is the amount of work obtainable when some matter is brought to a state of thermodynamic equilibrium with the common components of its surrounding nature by means of

reversible processes, involving interaction only with the above mentioned components of nature", in short it is defined as the maximum useful energy that can be obtained from the system when it proceeds from a particular state to the state of equilibrium with its surroundings. Gundersen et al., classified exergy for PVT systems as shown in Fig. 2.

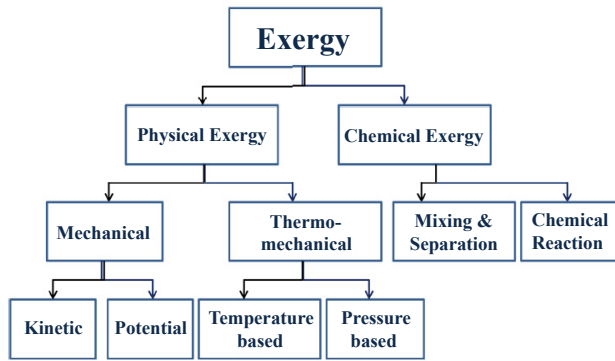

Fig. 2 Exergy classification

In this study, exergy transfer associated with material streams is considered in two ways: physical exergy transfer (thermal and mechanical) and chemical exergy transfer. Mechanical components of exergy transfer such as potential and kinetic exergies are neglected (Szargut et al., 1988).

Physical Exergy

Physical exergy is the maximum useful work obtained by passing unit mass of a substance from general state (T, P) to environmental state (T_0, P_0) (Kotas 1995; Javad et al., 2005; Chand et al., 2005). It can be considered as two parts- temperature based and pressure based parts. Temperature based part deals with the temperature change from T to T_0 at constant pressure whereas pressure based part deals with the pressure change from P to P_0 at constant temperature.

Physical exergy can be calculated as:

$$E_{ph} = (H - H_0) - T_0 (S - S_0) \quad (5)$$

For solids and liquids, the above equation can be expressed as follows (assuming a constant specific heat C_p):

$$e_{ph} = c_p \left\{ (T - T_0) - T_0 \ln \left(\frac{T}{T_0} \right) \right\} + V_m (P - P_0) \quad (6)$$

Where, V_m is the specific volume at temperature T_0 .

Chemical Exergy

Chemical exergy is defined as the maximum useful energy, which would be attained by passing from the environmental state to dead state.

Chemical exergy of pure component gases at a reference state/dead state can be calculated as follows (Jimenez Alvaro et al., 2015):

$$E_{ch} = RT_0 \ln \left(\frac{P_0}{P_{00}} \right) \quad (7)$$

Where, P_{00} is the partial pressure of the component in the reference state/dead state.

The chemical exergy for mixtures can be calculated as follows (Chand et al., 2013)

$$E_{ch, mix} = \sum_i (x_i * e_{ch, i}) + RT_0 \sum_i x_i \ln(\gamma_i * x_i) \quad (8)$$

Where, x_i is the mol fraction of the i th component, R is the molar gas constant and γ_i is the activity coefficient. For ideal solutions the activity coefficient is equal to one.

For many fuels (coal, oils, and petrol etc.) the chemical structure is unknown. The chemical exergy for these fuels can be estimated on the basis of lower heating value (LHV). The relation between the LHV and the chemical exergy (Chand et al., 2013) is

$$E_{ch} = \phi * LHV \quad (9)$$

Where, ϕ can be calculated by formulae based on the atomic composition. For different fuel oils and petrol, ϕ varies between 1.04 and 1.08.

Exergy Destruction Efficiency and Exergy Efficiency

According to first law of thermodynamics, energy is never destroyed during a process; it changes from one form to another form, so the total energy is conserved. In contrast, exergy is not conserved and destroyed by irreversibility of a process due to increase in entropy. Exergy is lost, when the energy associated with a material or energy stream is rejected to the environment.

Exergy destruction efficiency (y_D) is defined as the ratio of the rate of exergy destruction (ED) in a system to the input exergy rate to the system ($E_{F, total}$) (Tsatsaronis et al., 2007).

$$y_D = \frac{E_D}{E_{F, total}} * 100 \quad (10)$$

The rate of exergy destruction is the exergy loss in a system which can be calculated by subtracting the output exergy from input exergy.

The exergy efficiency is defined as the ratio of the rate of exergy out (E_{out}) to the rate of exergy in (E_{in}).

$$y_E = \frac{E_{out}}{E_{in}} * 100 \quad (11)$$

MODELING OF CHEMICAL LOOPING COMBUSTION (CLC)

In chemical looping combustion, direct contact between fuel and air will not happen, and the combustion takes place separately in two reactors- air reactor (AR) and fuel reactor (FR) as shown in

the flow sheet in Fig. 3. This system is simulated using Aspen Plus v8.1. Hence, the nomenclature of the models used for the present study are based on the Aspen Plus, which are widely used by different researchers in other studies (Wang et al., 2013; Al Doori., 2012; Meng., 2015; Smith et al., 2005). In these simulations, MIXCISLD is used as the stream class, which contains MIXED stream and CONVENTIONAL SOLIDS. RSTOIC reactors are used to model the air and fuel reactors in this study, as they can handle reactions that occur independently in a series of reactors and provide product selectivity and heat of reaction calculations. Gas-solid separator is modeled using component separator model in Aspen. All these models in Aspen plus flow sheet are solved in a sequential modular approach, where the mass and energy balance equations for different units are solved sequentially using tear streams in case of recycle streams. This involves multiple pass calculations for solving a system of linear/nonlinear equations to converge the tear stream. Selectivity analysis has been carried out for optimizing the values of solids flow rate as well as air flow rate. The temperature in the air reactor is fixed as 1200°C as it is usually limited by the melting point temperature of oxygen carrier (NiO, in this case). So, air reactor is modeled in isothermal condition, while the fuel reactor in adiabatic conditions. The air reactor outlet contains N₂ and un- reacted oxygen and these are

expanded in a gas turbine for power production. The entire process modeled in Aspen Plus is shown in Fig. 4.

The input, output, work and heat integration streams can be distinguished by the color of the lines as shown in Fig. 4. Green colour line represents the input and output streams, pink color line refers to heat integration stream and red colour represents work stream. Syn gas flow rate used in these simulations to produce 50 MW is 4 kg/s. Values of various other parameters considered for the present study are listed in Table 1.

Table 1. Values of parameters considered for the study

Parameter	Value
Fuel input	50 MW
Atmospheric conditions	25°C, 1.013 bar
Air reactor temperature	1200°C
Pressure	20 bar
Syngas composition at fuel reactor inlet	29.3% H ₂ , 50.7% CO, 6.9% CO ₂ , 12.6% H ₂ O, 0.45% N ₂
Fuel conversion efficiency	98%
Ni conversion rate in air reactor	98%
Compressor efficiency	85%
Isentropic efficiency of turbine	88%

The simulated results of the units are further used to calculate the exergy efficiencies and exergy

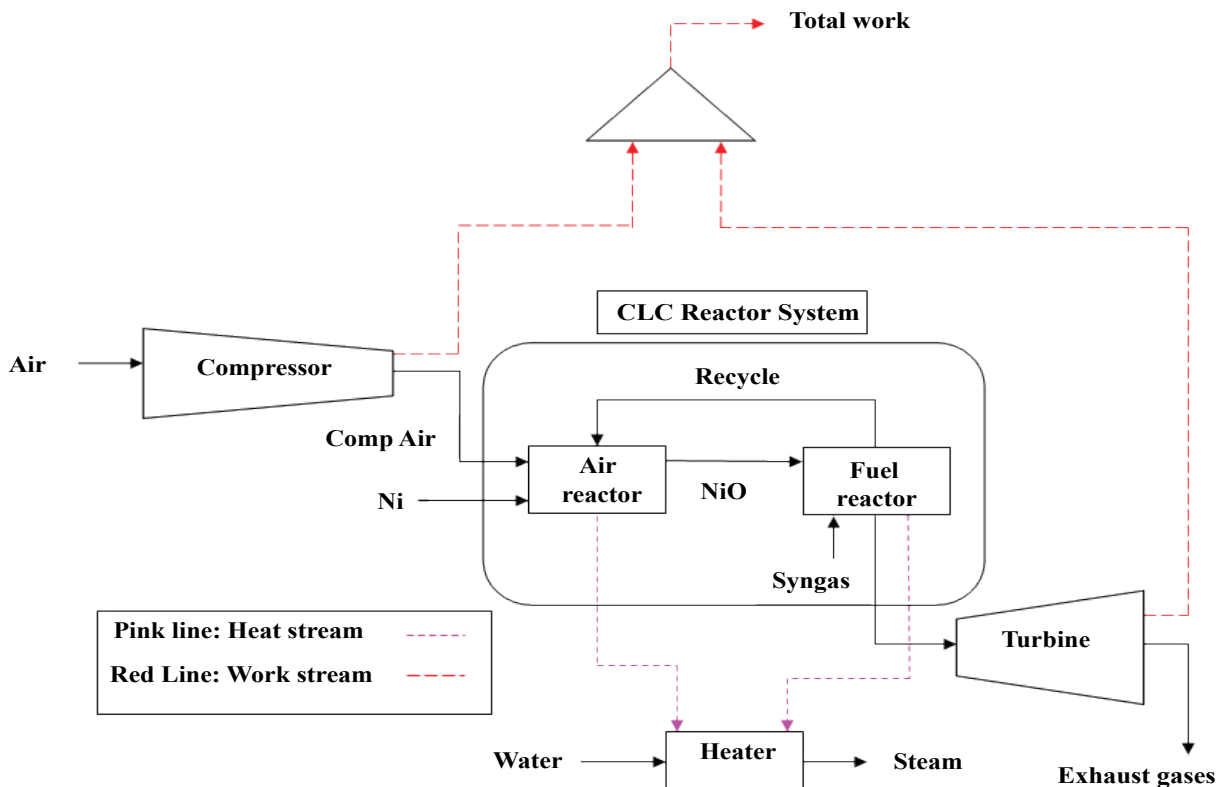

Fig. 3 Flow sheet for chemical looping combustion

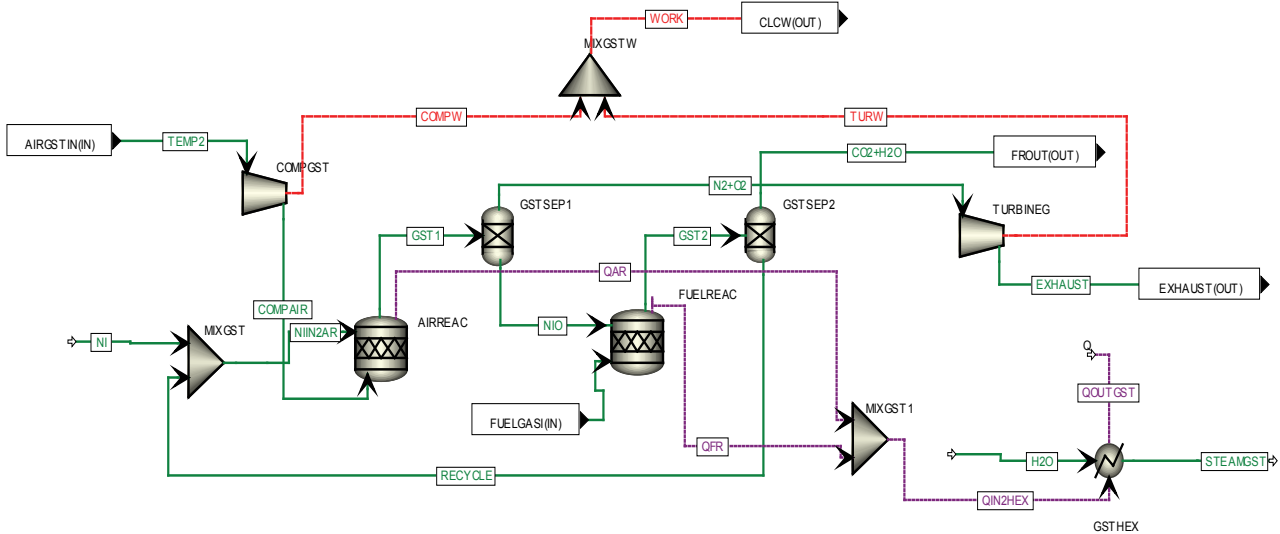

Fig. 4 Modelled chemical looping combustion in Aspen plus.

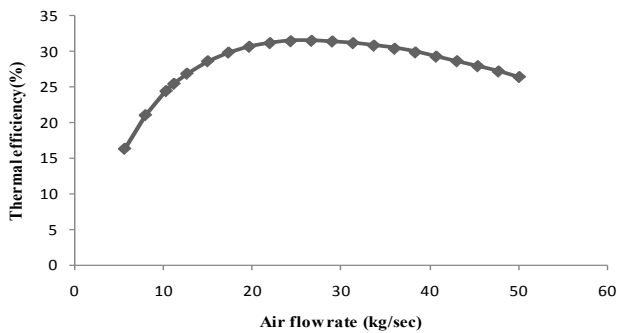

Fig. 5 Efficiency vs Air flow rate

destruction efficiencies of various units as discussed above.

RESULTS AND DISCUSSTIONS

Sensitivity analysis of air flow rate on the efficiency of the syngas fuelled power plant with CLC has been studied and is presented below. The exergy efficiency and destruction efficiency are also calculated for the plant and presented in this section.

Effect of air flow rate on the performance of thermal efficiency

Fig. 5 shows the effect of air flow rate on overall thermal efficiency of the syngas fuelled power plant. Overall thermal efficiency of the plant has been calculated as the ratio of net power generated (=total power generated–power consumption) to the total thermal energy of the input fuel (=flow rate × LHV). From Fig. 5, it can be observed that the efficiency of the plant increases to a maximum value and then decreases with increase in air flow rate. The net power generated depends on the temperature of the streams coming out from the air reactor which are going to the gas turbine. This in turn depends on the temperature of the air reactor.

An increase in air flow rate increases the air reactor temperature to a maximum value and then reduces gradually. The initial increase could be due to the oxidation of metal oxides from Ni to NiO. As the air flow rate increases, oxidation of solids also increases and since the oxidation is an exothermic reaction, the temperature also increases. But after the solids are completely oxidized, the excess amount of air provides a cooling effect as it takes sufficient amount of heat to get heated up. This causes a decrease in air reactor temperature, which further reduces the net power generated, hence the efficiency of the plant. The optimum air flow rate of 22 kg/s corresponding to the peak thermal efficiency of about 31.2% has been chosen for further analysis.

Exergy efficiency (y_E) and Exergy destruction efficiency (y_D) of different units in the CLC integrated syngas fuelled power plant.

The main difference between energy and exergy is that energy is conserved whereas some exergy is destroyed. Exergy destruction can take place due to the irreversibilities of the process (heat transfer, chemical reaction, mixing etc.) or it can be lost due to leakage (release in purge, bleed streams or cooling water). The input and output exergies for each unit have been calculated. From these values, efficiency is calculated in order to understand the total exergy utilizable to the system. An efficiency based on total exergy is calculated considering only the irreversibility of the system neglecting the losses.

The physical and chemical exergy values have been calculated using the eq. 5 and eq. 8. The standard values of enthalpy and entropy for different components involved in the process are presented in Table A1 of Appendix-1 (Smith et al., 2005). These values are used to calculate the standard enthalpy

and entropy of the mixture of gases, which are further used to calculate the physical exergy values. The standard chemical exergy values (Smith *et al.*, 2005) used for different components and presented in Table A2 of Appendix-1. These are used to calculate the chemical exergy of mixture streams from environmental state to reference state.

The total exergy is calculated from the sum of physical and chemical exergy values. These are further used to obtain the exergy efficiency and exergy destruction efficiency for each unit using eq. 11 and 10 respectively. The calculated exergy efficiency and exergy destruction efficiency values are listed in the following Table 2.

Table 2. Exergy efficiency Vs. different components in CLC system

S. No.	Components	Exergy efficiency (%)	Exergy destruction efficiency (%)
1	Compressor	81	19
2	Mixer	99	1
3	Air reactor	90	10
4	Seperator1	98	2
5	Fuel reactor	65	35
6	Seperator2	67	33
7	Turbine	82	18

The values of exergy efficiency and exergy destruction efficiency of different units in CLC integrated syngas fuelled power plant are plotted in Fig. 6. It can be observed that, the exergy efficiency of compressor and turbine are more compared to that of fuel reactor. Of all the units, it can be observed that the exergy efficiency is less for the fuel reactor and separator 2. Exergy efficiency in fuel reactor could be low due to high syngas flow rate, which has high quantity of exergy of CO.

Fig. 7 represents the distribution of total exergy destruction efficiency of different units. This also shows that fuel reactor has high destruction efficiency. Hence, the exergy analysis presented through Figures 6 and 7 help in identifying the units, where the maximum exergy is destroyed. This gives a direction to focus on the units which cause high exergy destruction efficiency, in order to increase the overall plant thermal efficiency. The study helps in identifying the units to be improved in future to operate the plant efficiently and economically.

CONCLUSIONS

Exergy analysis is performed for chemical looping combustion integrated 50 MW syngas fuelled power plant. Thermal efficiency of the plant is found to be 31.2%. Effect of air flow rate on overall thermal efficiency of the syngas fuelled power plant is analyzed. An initially increasing graph followed by

decreasing tendency indicates the necessity of using optimum flow rate of air, which was calculated and found out to be 22 kg/s for 4 kg/s of fuel. Exergy destruction is observed to be more in fuel reactor. From the exergy efficiency and exergy destruction efficiency analysis, it can be concluded that the overall plant efficiency can be improved by focusing the attention on fuel reactor than any other units.

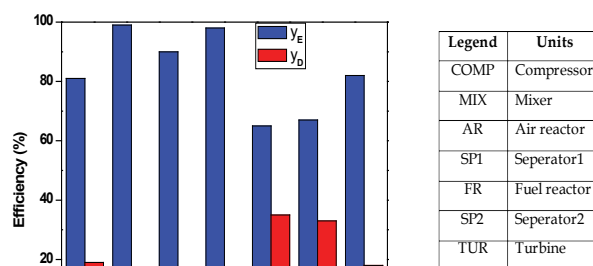

Fig. 6 Exergy efficiency (y_e) and exergy destruction efficiency (y_d) of different units

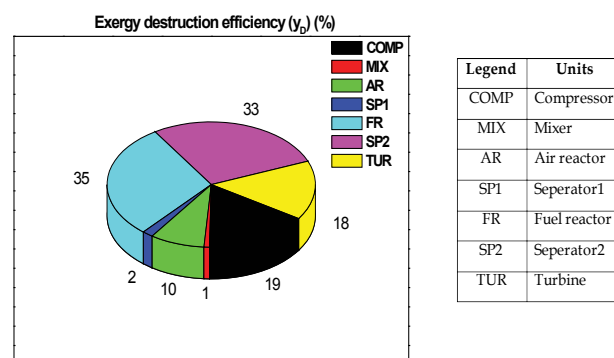

Fig. 7 Exergy destruction efficiency (y_d) of different units

ACKNOWLEDGEMENTS

Authors acknowledge the Science and Engineering Research Board (SERB), Government of India for supporting this work through a sponsored project (SB/FTP/ETA-0421/2013).

REFERENCES

- Figueroa JD, Fout T, Plansynski S, Mcllvried H, Srivastava RD. 2008. Advances in CO₂ capture technology-The U.S department of energy's, carbon sequestration program. International Journal of Greenhouse Gas Control. 2: 9-20.
- Adanez J, Abad A, Labiano FG. 2012. Progress in Chemical-Looping Combustion and Reforming technologies. Progress in Energy and Combustion Science. 38: 215-282.
- Erlach B, Schmidt M, Tsatsaronis G. 2011. Comparison of Carbon Capture IGCC with Pre-combustion Decarbonisation and with Chemical-Looping Combustion. Energy. 36: 3804-3815.
- Bilgen S, Kaygusuz K. 2008. The calculation of the

- chemical exergies of coal-based fuels by using the higher heating values. *Applied Energy*. 85: 776-785.
- Wang D, Chen S, Xu Ch, Xiang W. 2013. Energy and exergy analysis of a new hydrogen-fueled power plant based on calcium looping process. *Int. J. Hydrogen*. 38: 5389-5400.
- Jimenez Alvaro A, Paniagua IL, Gonzalez Fernandez C, Carlier RN, Martin JR. 2014. Energetic analysis of a syngas-fueled chemical looping combustion combined cycle with integration of carbon dioxide sequestration. *Energy*. 76: 694-703
- Jimenez Alvaro A, Paniagua IL, Gonzalez Fernandez C, Carlier RN, Martin JR. 2015. Simulation of an integrated gasification combined cycle with chemical-looping combustion and carbon dioxide sequestration. *Energy Conversion and Management*. 104: 170-179.
- Kaushik SC, Siva Reddy V, Tyagi SK. 2011. Energy and exergy analyses of thermal power plants: A review. *Renewable and Sustainable Energy Reviews*. 15: 1857-1872.
- Al Doori WH. 2012. Exergy analysis of a gas turbine performance with effect cycle temperatures. *International Journal of Research and Reviews in Applied Sciences*. 13: 549-556.
- Erlach B, Schmidt M, Tsatsaronis G. 2011. Comparison of carbon capture IGCC with pre-combustion decarbonisation and with chemical-looping combustion. *Energy*. 36: 3804-3815
- Mukherjee S, Kumar P, Yang A, Fennell P. 2015. Energy and exergy analysis of chemical looping combustion technology and comparison with pre-combustion and oxy-fuel combustion technologies for CO₂ capture. *Journal of Environmental Chemical Engineering*. 3: 2104-2114 .
- Szargut J, Morris DR, Steward FR. 1988. *Exergy Analysis of Thermal, Chemical and Metallurgical Processes*. pp332 Hemisphere Publishing Corporation.
- Gundersen T. 2011. An Introduction to the concept of Exergy and Energy quality. Dept. of Energy and Process Engg, NUST, Norway, version 4.
- Kotas TJ. 1995. *The Exergy Method of Thermal Plant Analysis*. Krieger Publishing Company, Malabar, Florida.
- Javad M, Mofid E. 2005. Exergetic Analysis of Gas Turbine Plants. *Int J Exergy*. 2: 31-39
- Chand TV, Ravi Sankar B, Chowdary RJ. 2013. Exergy Analysis of Gas Turbine Power Plant. *International Journal of Engineering Trends and Technology*. 4: 3991-3993.
- Tsatsaronis G. 2007. Definitions and Nomenclature in Exergy Analysis and Exergoeconomics. *Energy*. 32: 249-253
- Meng WX, Banerjee S, Zhang X, Agarwal RK. 2015. Process simulation of multi-stage chemical-looping combustion using Aspen Plus. *Energy*. 90: 1869-1877
- Smith JM, Van Ness HC, Abbott MM. 2005. *Introduction to Chemical Engineering Thermodynamics*. (7th edn).